

Crown Typical Aluminum Blocks Installation Instructions

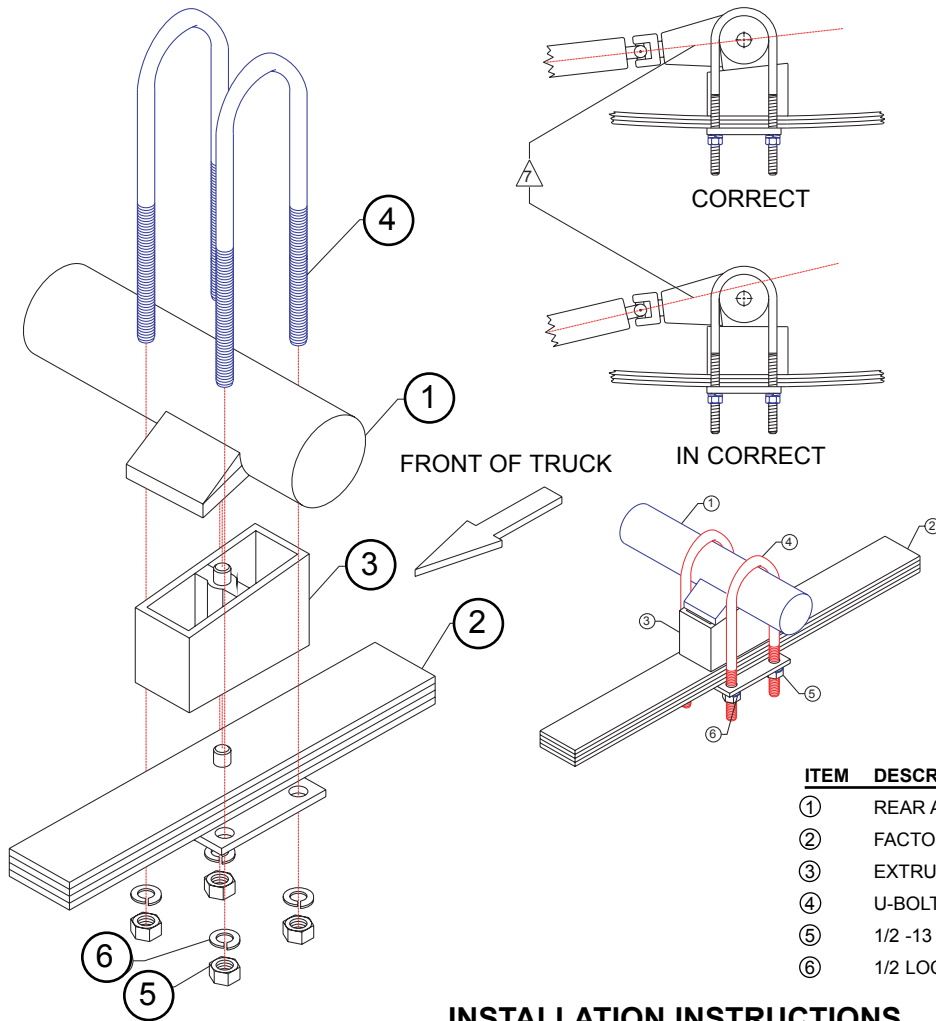

ITEM	DESCRIPTION	MATERIAL/SPEC
①	REAR AXLE	STEEL
②	FACTORY LEAF SPRINGS	STEEL
③	EXTRUDED LOWERING BLOCKS	ALUMINUM
④	U-BOLTS	STEEL
⑤	1/2 -13 HEX NUTS	
⑥	1/2 LOCK WASHERS THINGS TO CONSIDER	

INSTALLATION INSTRUCTIONS

1. LOWERING BLOCKS ARE NOT TO BE USED IN CONJUNCTION WITH ANY OTHER LOWERING METHODS.
2. DO NOT STACK LOWERING BLOCKS.
3. MAKE SURE THAT ALL PART ARE FREE FROM CONTACT WITH LOWERING BLOCK. (BRAKE LINES, BRAKE CABLES, SHOCK ABSORBERS, AND ANY OTHER PART THAT MAY INTERFERE).
4. BE SURE TO RE CHECK TORQUE ON THE NUTS EVERY 30 DAY.
5. MUST BE INSTALLED BY A QUALIFIED TECH.

1. LOWERING BLOCKS ARE NOT TO BE USED IN CONJUNCTION WITH ANY OTHER LOWERING METHODS.
2. DO NOT STACK LOWERING BLOCKS.
3. MAKE SURE THAT ALL PART ARE FREE FROM CONTACT WITH LOWERING BLOCK. (BRAKE LINES, BRAKE CABLES, SHOCK ABSORBERS, AND ANY OTHER PART THAT MAY INTERFERE).
4. BE SURE TO RE CHECK TORQUE ON THE NUTS EVERY 30 DAY.
5. MUST BE INSTALLED BY A QUALIFIED TECH.

1. READ AND UNDERSTAND ALL INSTRUCTIONS. MUST BE INSTALLED BY A QUALIFIED TECH.
2. LIFT VEHICLE AND SET FRAME ON JACK STANDS. REMOVE WHEELS FOR WORKING CLEARANCE.
3. SUPPORT REAR AXLE WITH FLOOR JACK.
4. NOW YOU MAY REMOVE YOUR FACTORY U BOLTS AND WITH YOUR JACK LIFT REAR AXLE ENOUGH TO INSERT YOUR LOWERING BLOCKS.
5. CHECK AND BE SURE THAT LOWERING BLOCKS ARE PROPERLY ALIGNED WITH VEHICLE. TIGHTEN AND TORQUE ALL NUTS TO 75 FT. LBS.
6. DRIVE TWO MILES AND RE TORQUE ALL NUTS. NUTS MUST BE RE CHECKED EVERY 30 DAYS.
7. CHECK AND MAKE SURE THAT PINION ANGLE IS CORRECT.

THINGS TO CONSIDER

1. LOWERING BLOCKS ARE NOT TO BE USED IN CONJUNCTION WITH ANY OTHER LOWERING METHODS.
2. DO NOT STACK LOWERING BLOCKS.
3. MAKE SURE THAT ALL PART ARE FREE FROM CONTACT WITH LOWERING BLOCK. (BRAKE LINES, BRAKE CABLES, SHOCK ABSORBERS, AND ANY OTHER PART THAT MAY INTERFERE).
4. BE SURE TO RE CHECK TORQUE ON THE NUTS EVERY 30 DAY.
5. MUST BE INSTALLED BY A QUALIFIED TECH.